

# TIPI F

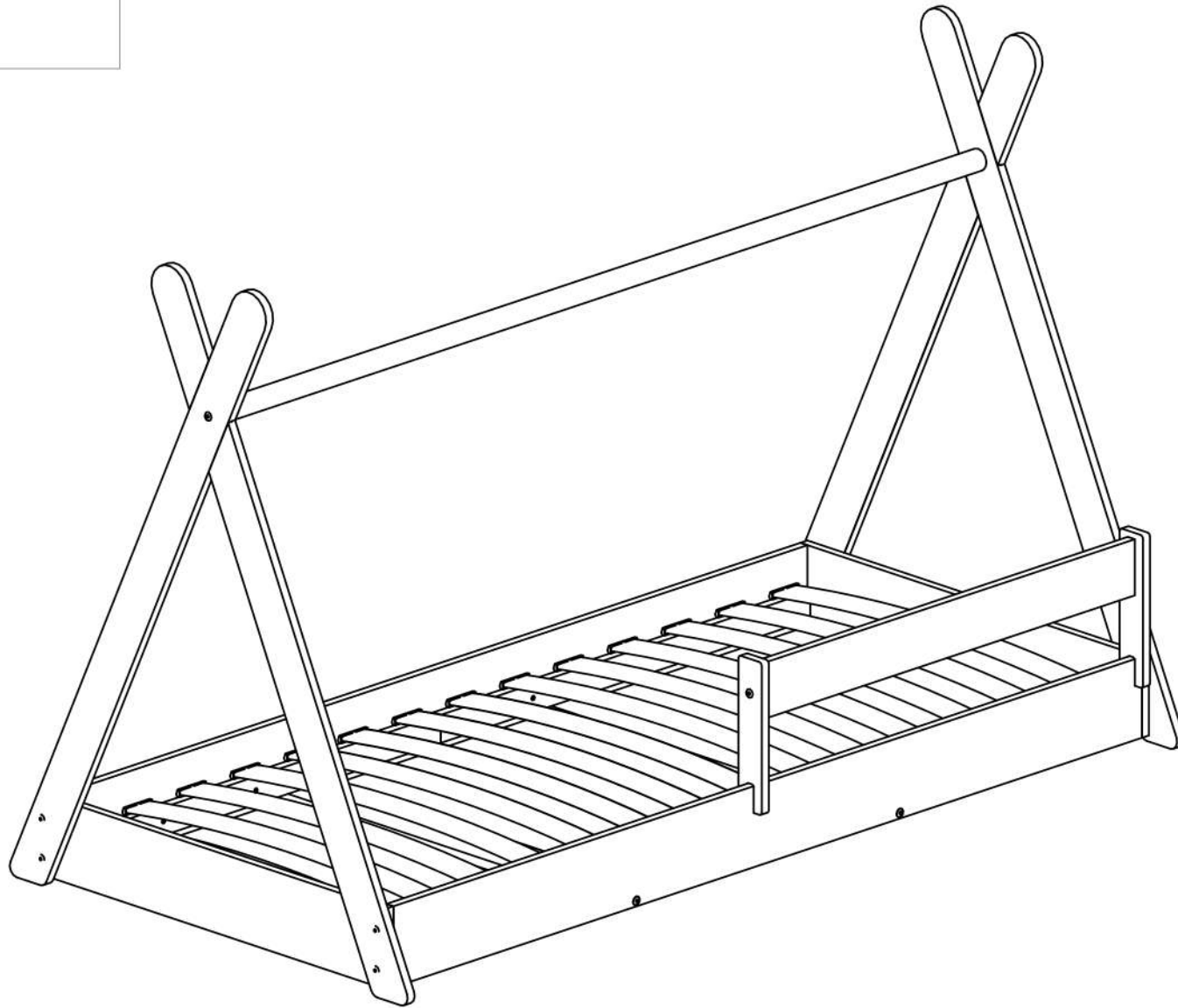

## PLEASE READ BEFORE ASSEMBLY

- 1) Make sure there is enough free space for installation.
- 2) Before fully unpacking, please measure the elements whether they match the order.
- 3) After unpacking the elements from the boxes, please check the completeness of the set with the assembly instructions – if you find that something is missing – let us know and if necessary, we will send the missing parts.
- 4) Consider whether you will need help with assembly, if you find it necessary, find someone to help you.  
(For bunk beds assembly, we recommend two people).
- 5) The installation of wooden dowels must be done on a solid, flat surface. By using a hammer in this process, remember not to use too much force.

REMEMBER!

NEVER HAMMER WOODEN DOWELS IN THE AIR OR WITHOUT SUPPORT!

# RECOMMENDED ASSEMBLY TOOLS

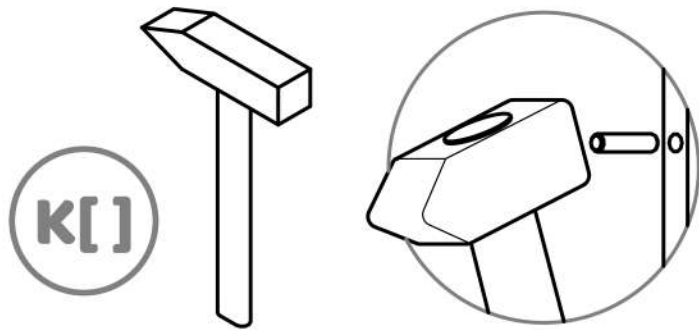

K[ ]

HAMMER for DOWELS

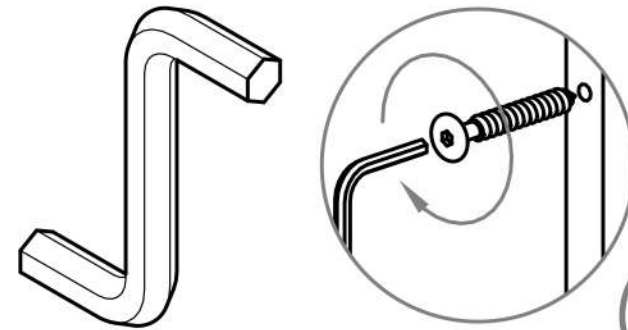

S[ ]

Included in assembly kit!

ALLEN KEY for SCREWS

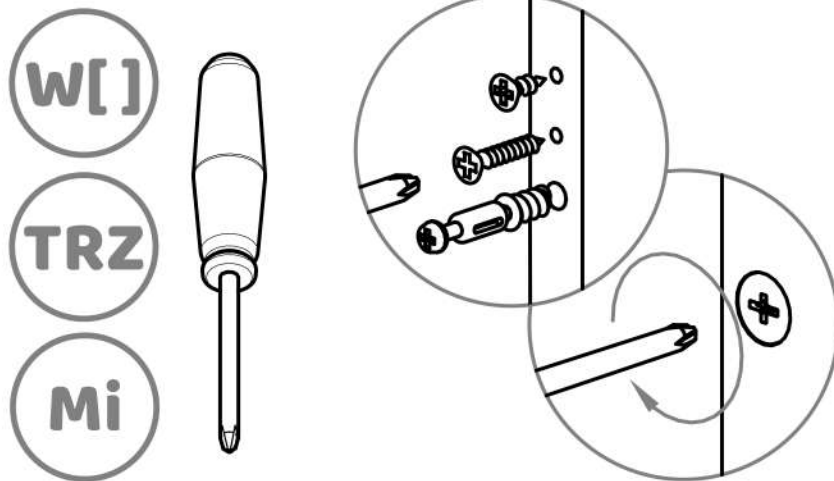

W[ ]

TRZ

Mi

SCREWDRIVER for  
BOLTS & ECCENTRICITIES

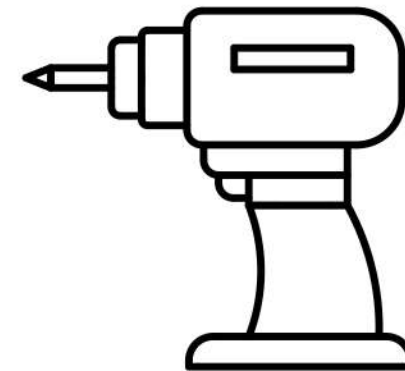

CORDLESS SCREWDRIVER

To avoid damaging furniture  
use only low power mode

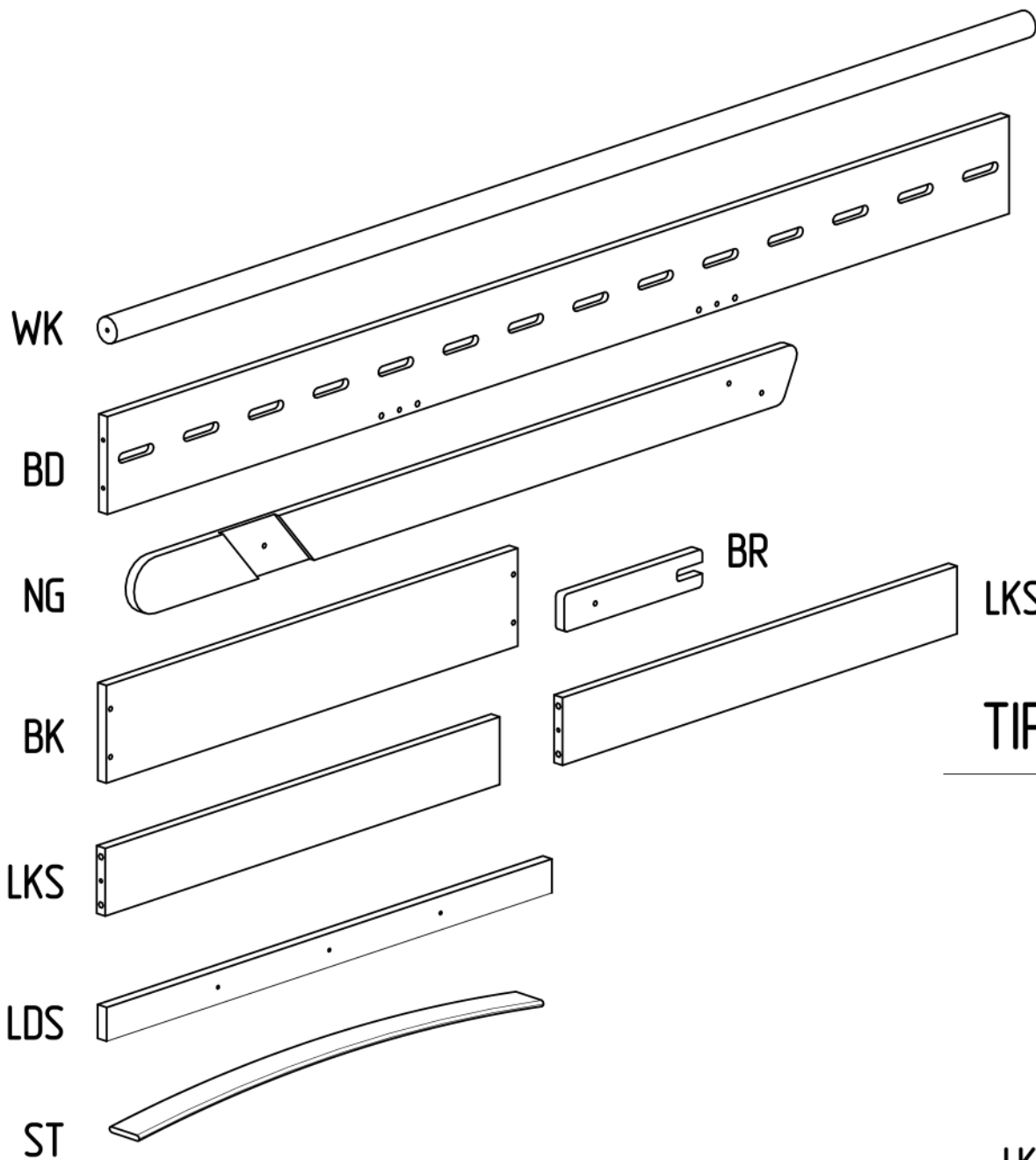

SCREWS	
S60	x8
S50	x8
K8	x12
W25	x12
PL	x20-32

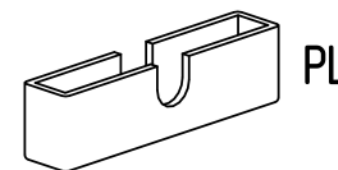
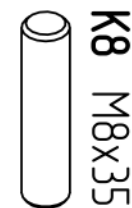
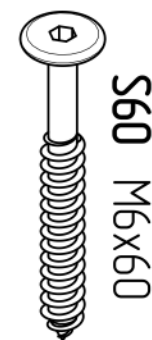

WK	x1
BD	x2
NG	x4
BK	x2
BR	x2
LKS	x2
LKS BR	x1
LDS	x4
ST	x10-16

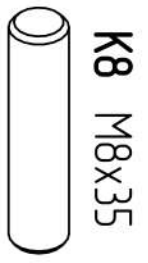
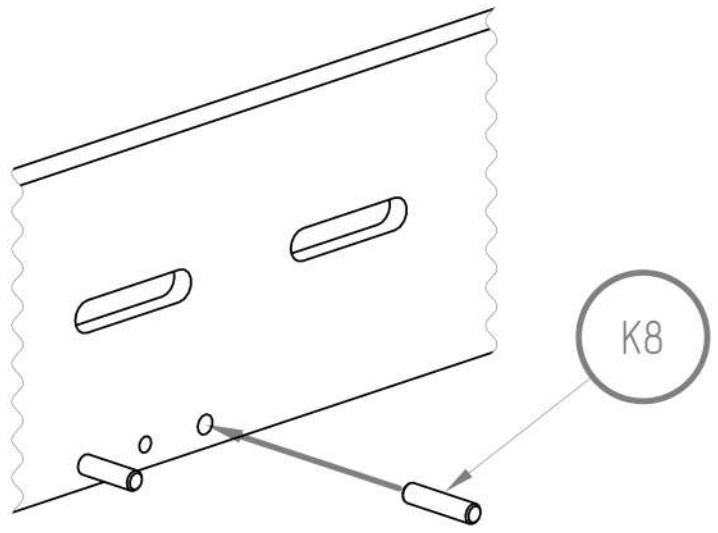
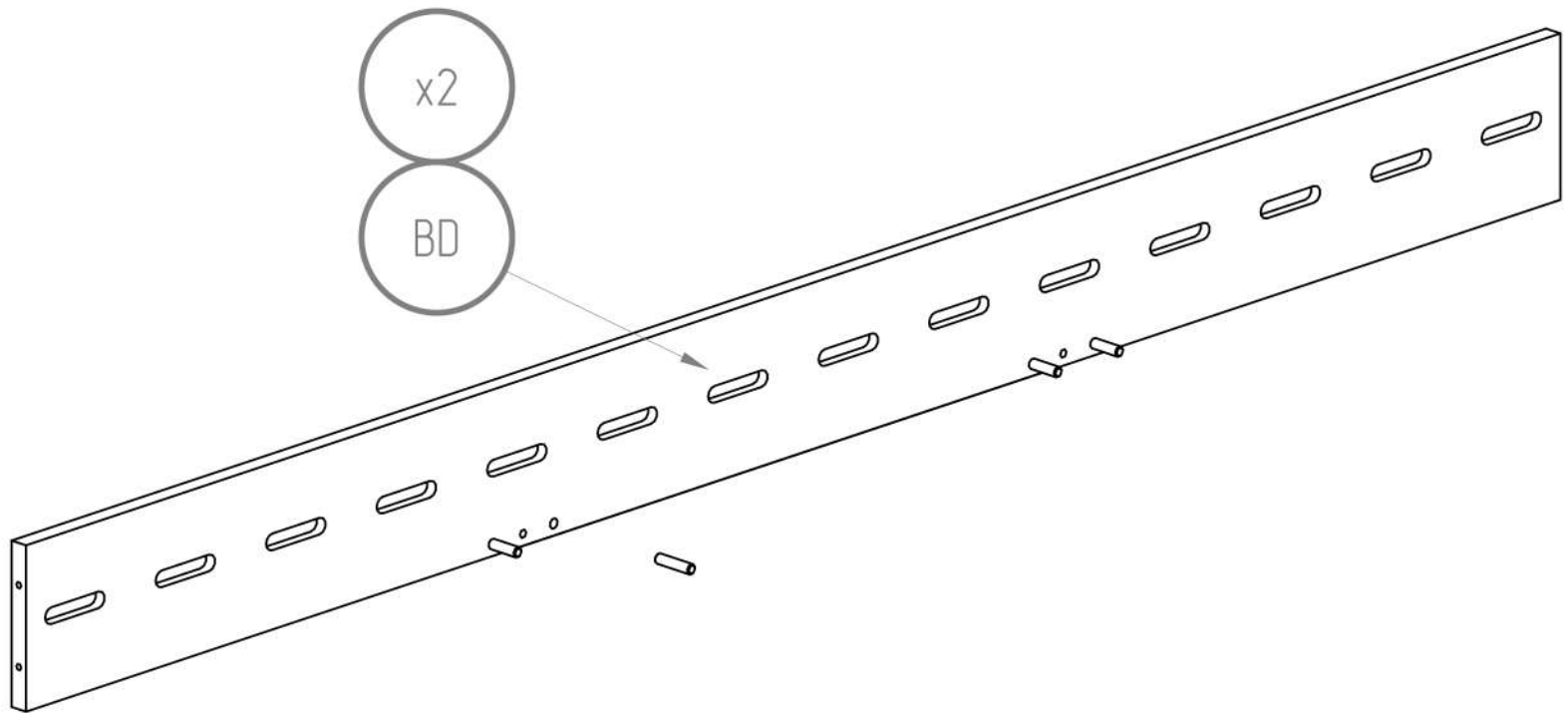

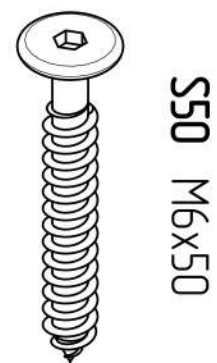
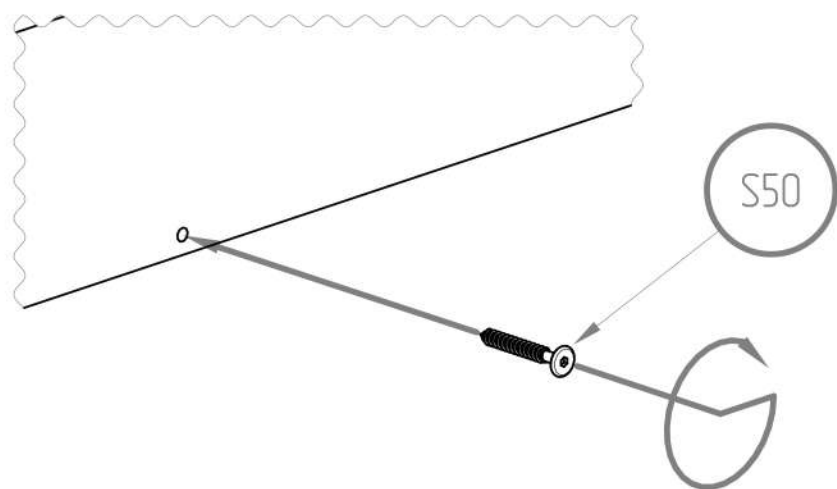
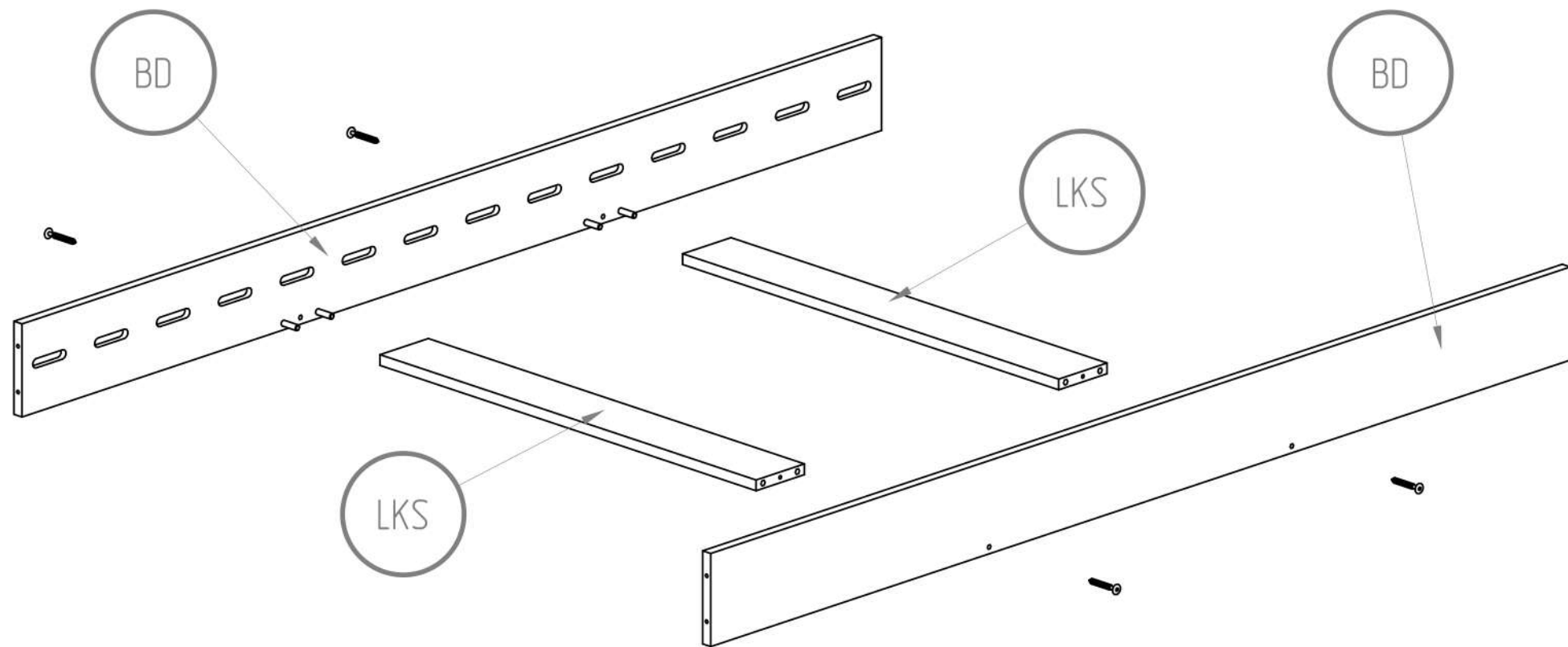

DO THIS ASSEMBLY TWICE

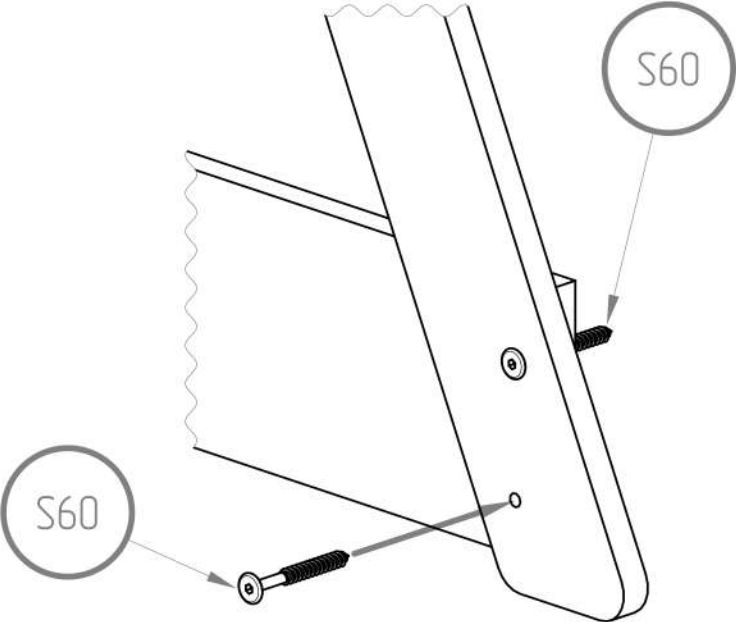
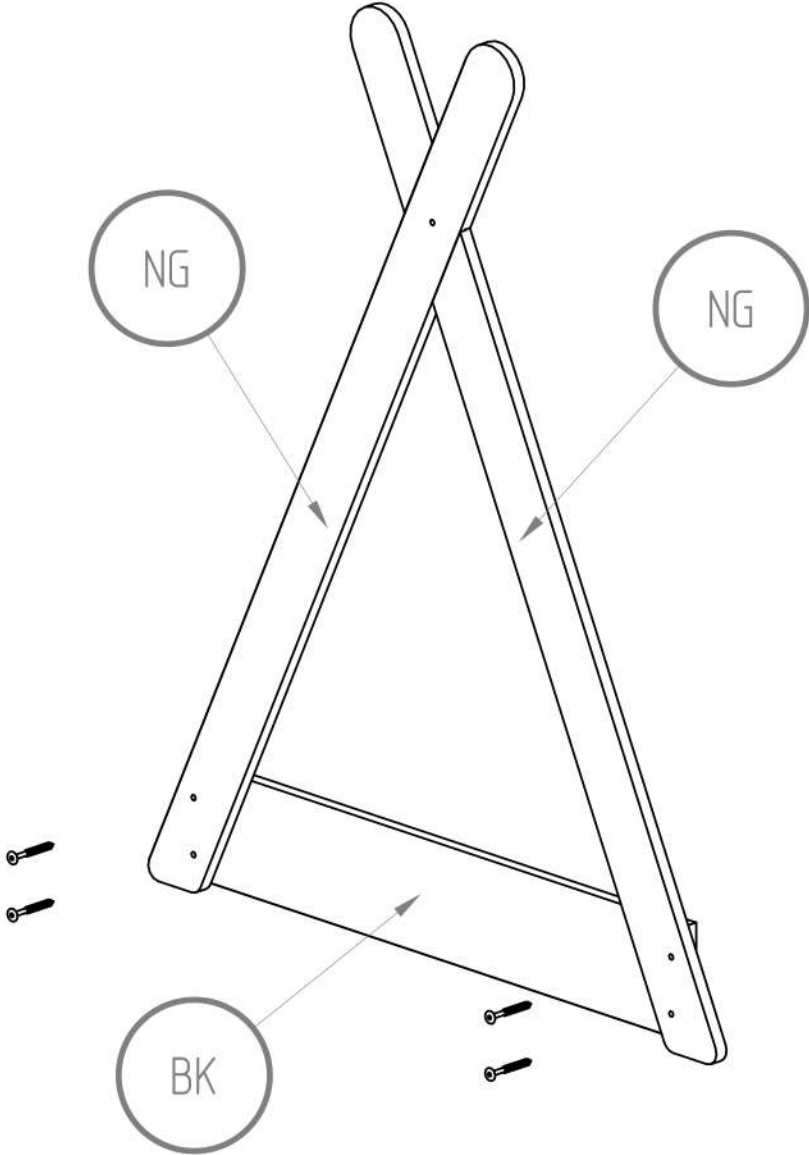

1 STEP

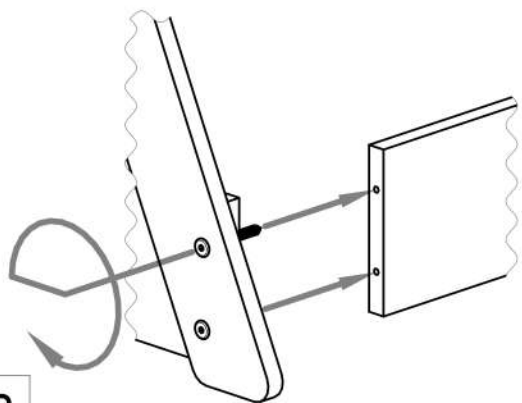

WK

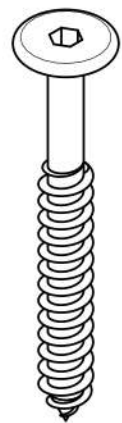
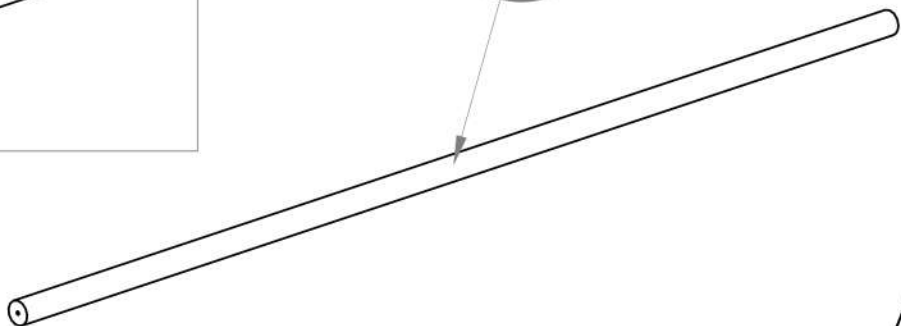

S60 M6x50

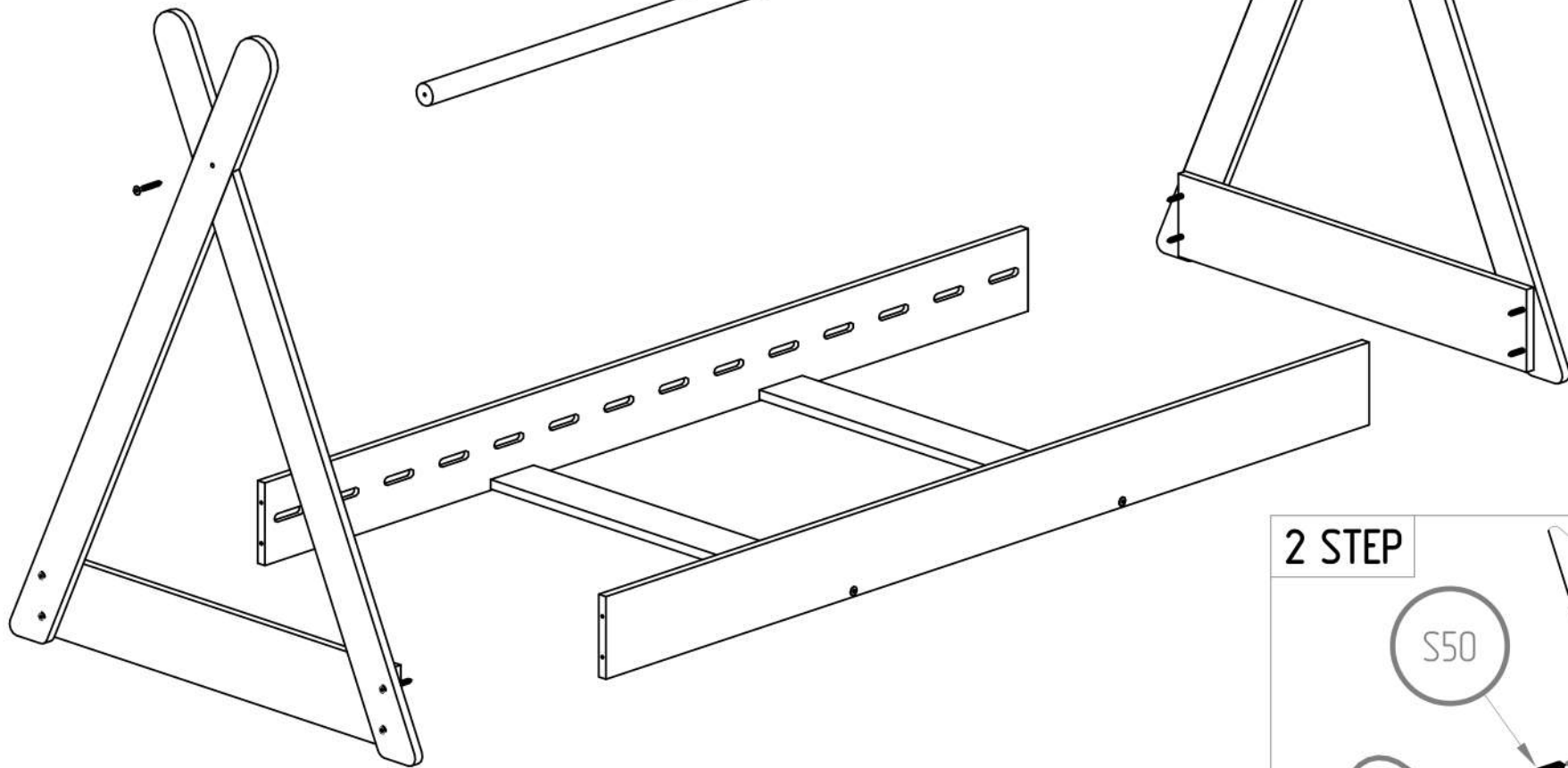

2 STEP

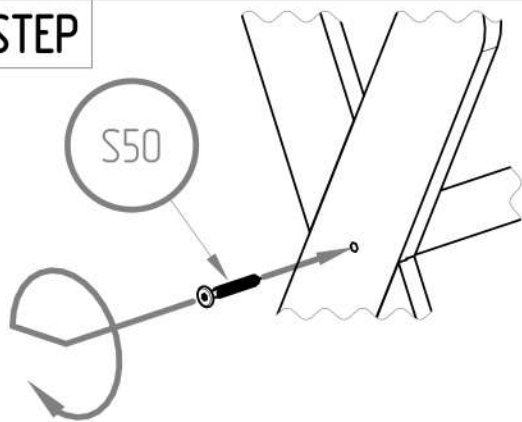

S50

5



W25 M4x25

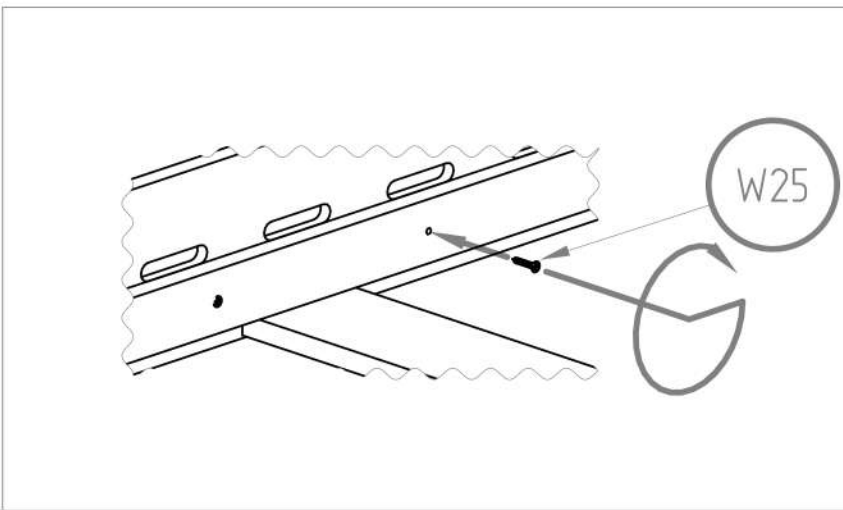
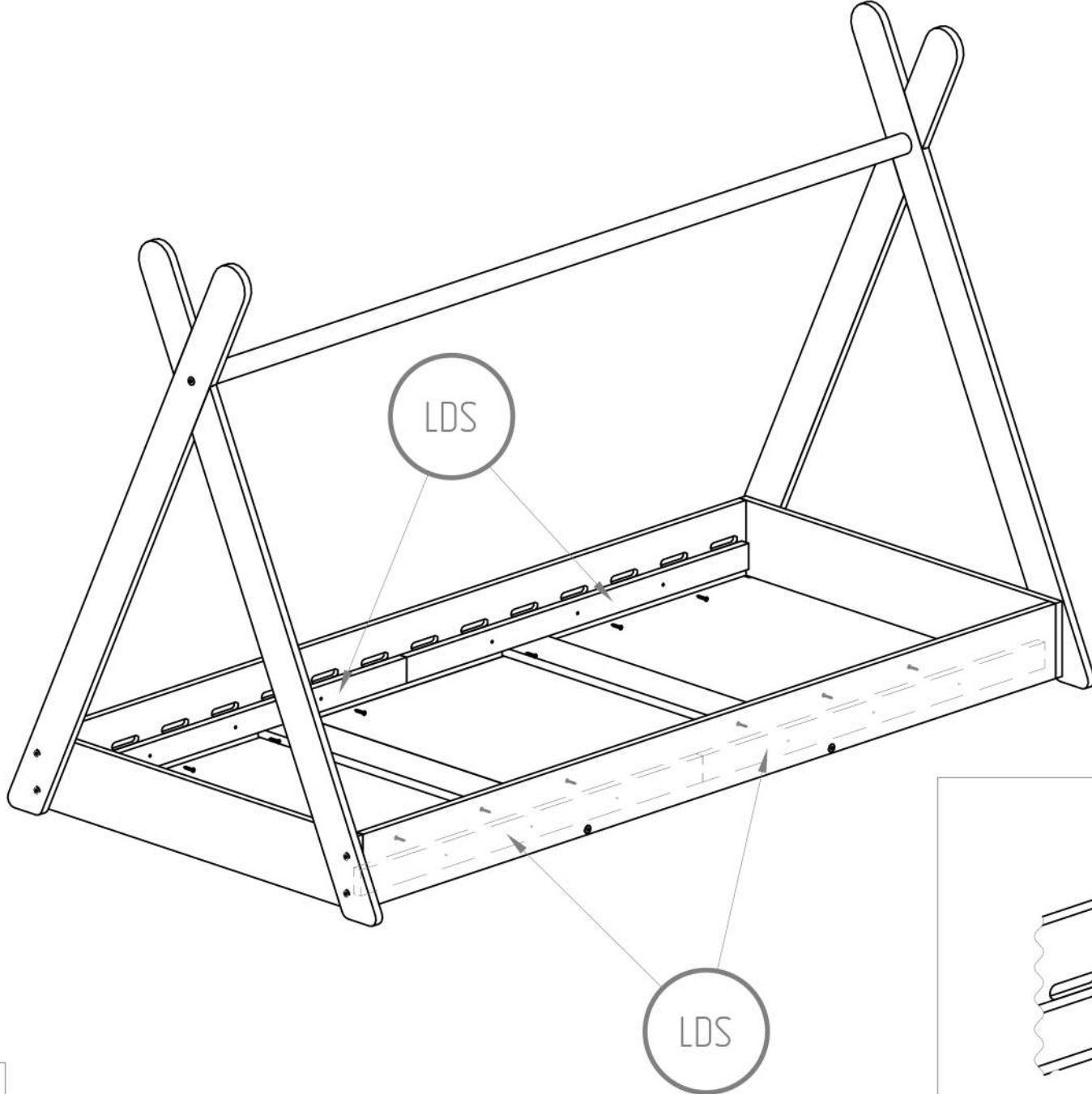

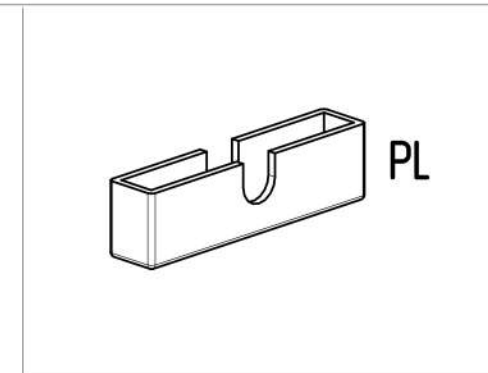
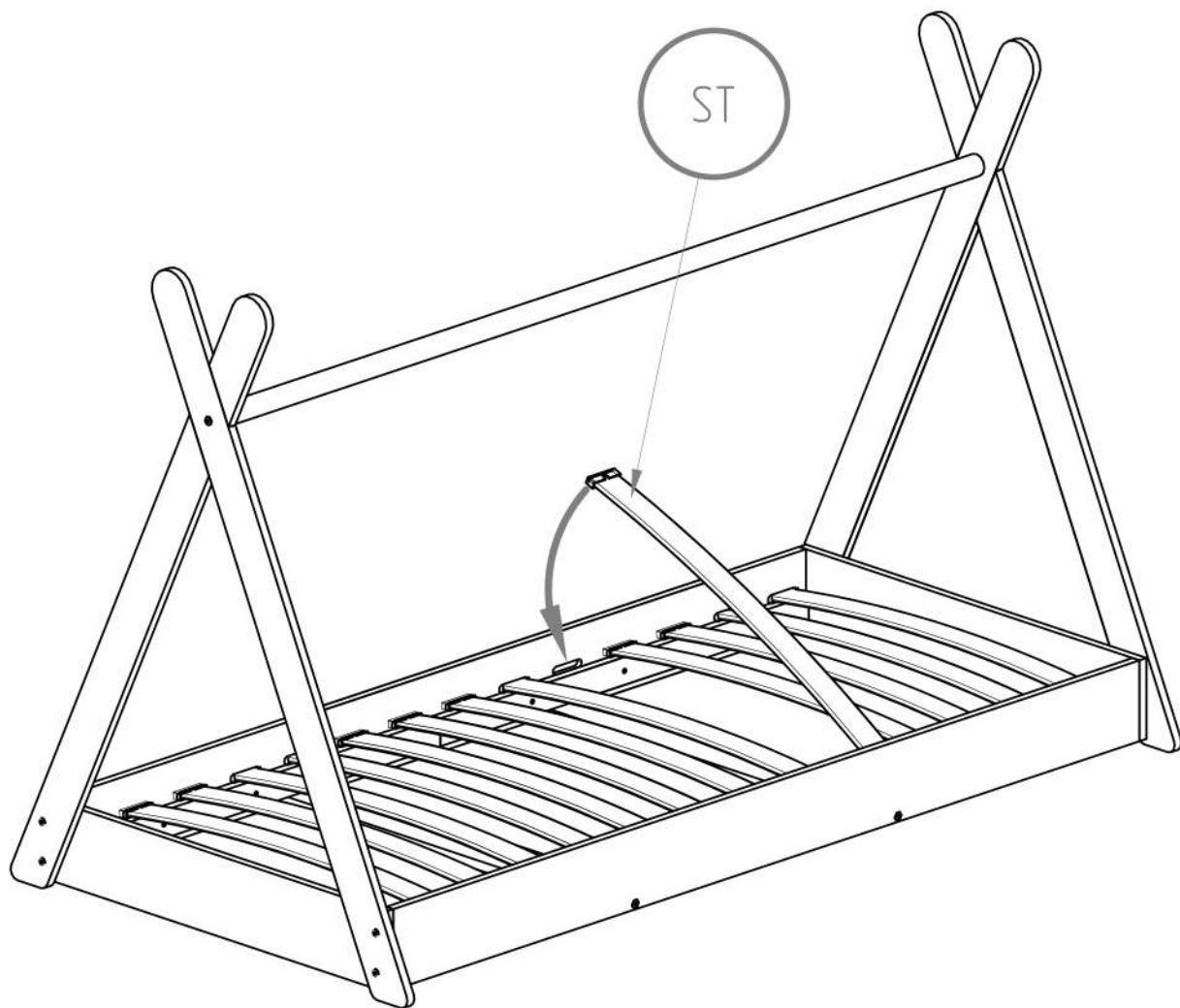

### Important!

Install the plastic caps before assembling the ST spring slats to the bed frame.

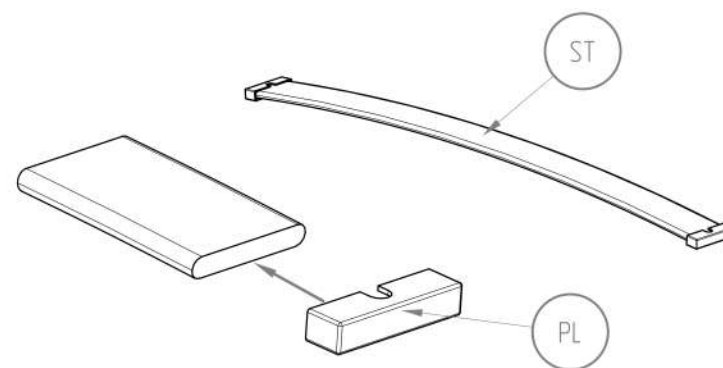

# BARRIER

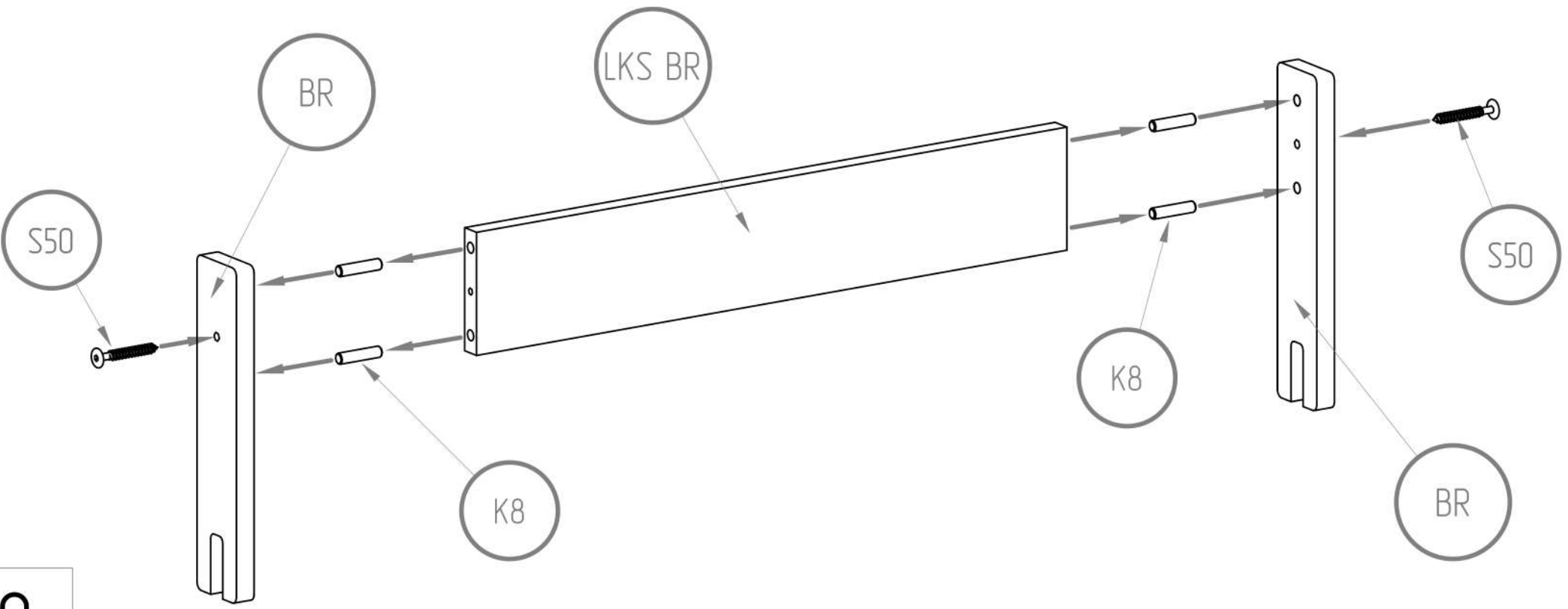
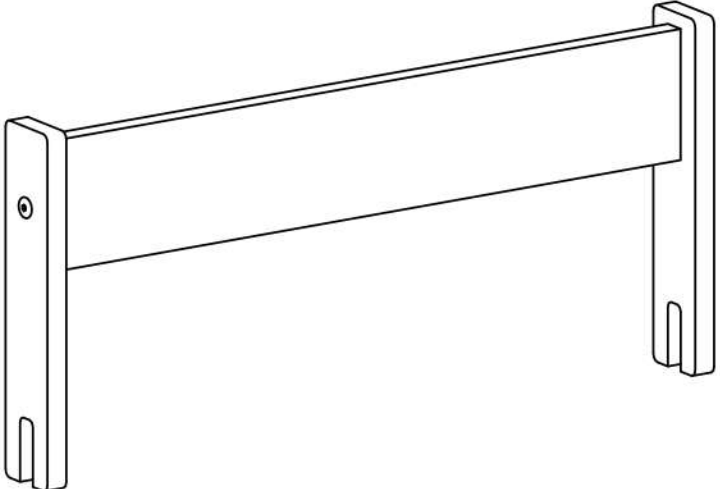

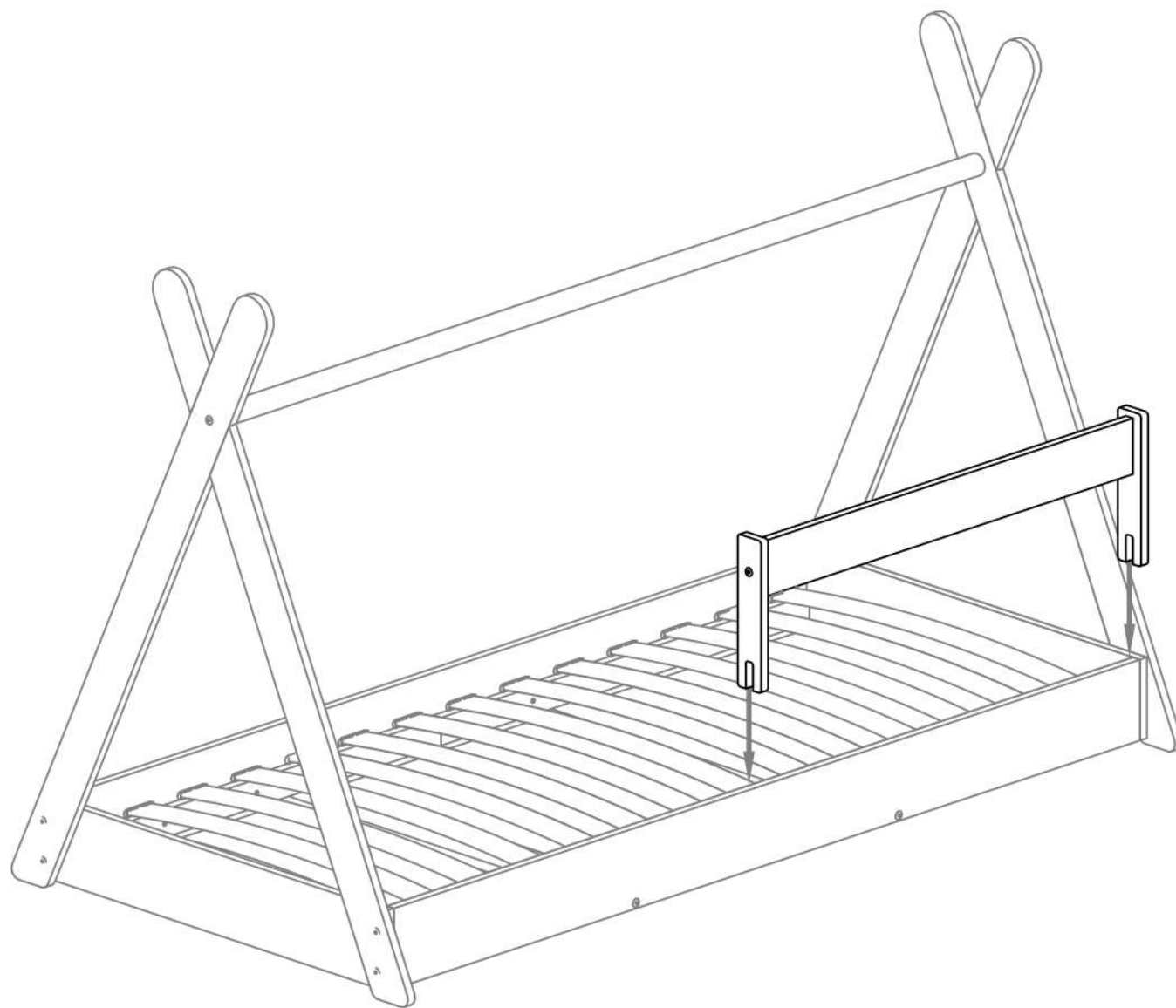



**UWAGA  
WAŻNE**

**ATTENTION  
IMPORTANT**

**ACHTUNG  
WICHTIG**

**ATTENTION  
IMPORTANTE**

**ATTENZIONE  
IMPORTANTE**

**ATENCIÓN  
IMPORTANTE**



Max. grubość materaca to 12 cm. Rekomendujemy materace o grubości 8-12 cm. Wymiar materaca musi odpowiadać wymiarowi łóżka.

Max. mattress thickness is 12 cm. We recommend mattresses with a thickness of 8-12 cm. The mattress size must match the bed size.

Max. Matratzenstärke beträgt 12 cm. Wir empfehlen Matratzen mit einer Stärke von 8-12 cm. Die Matratzengröße muss der Bettgröße entsprechen.

Épaisseur maximale du matelas : 12 cm. Nous recommandons des matelas d'une épaisseur de 8 à 12 cm. La taille du matelas doit correspondre à la taille du lit.

Spessore massimo del materasso: 12 cm. Raccomandiamo materassi con uno spessore di 8-12 cm. Le dimensioni del materasso devono corrispondere alle dimensioni del letto

Grosor máximo del colchón: 12 cm. Recomendamos colchones con un grosor de 8-12 cm. El tamaño del colchón debe coincidir con el tamaño de la cama.



Maksymalne obciążenie łóżka: 230 kg.

Maximum load for the bed: 230 kg.

Maximale Belastung für das Bett: 230 kg.

Charge maximale du lit: 230 kg.

Carico massimo del letto: 230 kg.

Carga máxima de la cama: 230 kg.



Zakaz skakania na łóżku. Grozi uszkodzeniem.

No jumping on the bed. Risk of damage.

Springen auf dem Bett verboten. Gefahr von Beschädigungen.

Interdiction de sauter sur le lit. Risque de dommages.

Vietato saltare sul letto. Rischio di danni.

Prohibido saltar en la cama. Riesgo de daño.



Nie używaj łóżka, jeśli jakkolwiek jego część jest uszkodzona lub brakuje elementów.

Do not use the bed if any part is damaged or if there are missing components.

Benutzen Sie das Bett nicht, wenn ein Teil beschädigt ist oder Teile fehlen.

N'utilisez pas le lit si une partie est endommagée ou si des éléments sont manquants.

Non utilizzare il letto se una parte è danneggiata o se mancano dei componenti.

No uses la cama si alguna parte está dañada o falta algún componente.



**UWAGA  
WAŻNE**

**ATTENTION  
IMPORTANT**

**ACHTUNG  
WICHTIG**

**ATTENTION  
IMPORTANTE**

**ATTENZIONE  
IMPORTANTE**

**ATENCIÓN  
IMPORTANTE**



Regularnie sprawdzaj, czy wszystkie mocowania są dobrze dokręcone.

Regularly check that all fasteners are properly tightened.

Überprüfen Sie regelmäßig, ob alle Befestigungen gut angezogen sind.

Vérifiez régulièrement que tous les fixations sont bien serrées.

Controlla regolarmente che tutte le fissaggi siano ben stretti.

Revisa regularmente que todos los elementos de sujeción estén bien apretados.



Zawsze postępuj zgodnie z instrukcjami montażu i użytkowania producenta.

Always follow the manufacturer's assembly and usage instructions.

Befolgen Sie immer die Montage- und Gebrauchsanweisungen des Herstellers

Suivez toujours les instructions de montage et d'utilisation du fabricant.

Segui sempre le istruzioni di montaggio e utilizzo del produttore.

Siempre sigue las instrucciones de montaje y uso del fabricante.



Korzystaj wyłącznie z oryginalnych części zamiennych dostarczonych przez producenta.

Use only original spare parts supplied by the manufacturer.

Verwenden Sie nur originale Ersatzteile, die vom Hersteller geliefert werden.

Utilisez uniquement des pièces de rechange d'origine fournies par le fabricant.

Utilizza solo pezzi di ricambio originali forniti dal produttore.

Utiliza únicamente piezas de repuesto originales proporcionadas por el fabricante.



Zapewnij odpowiednią wentylację pomieszczenia, aby uniknąć pleśni.

Ensure proper ventilation in the room to avoid mold.

Sorgen Sie für eine angemessene Belüftung des Raumes, um Schimmel zu vermeiden.

Assurez une ventilation adéquate de la pièce pour éviter la moisissure.

Assicurati di ventilare adeguatamente la stanza per evitare la muffa.

Asegúrate de proporcionar una ventilación adecuada en la habitación para evitar el moho.



**UWAGA  
WAŻNE**

**ATTENTION  
IMPORTANT**

**ACHTUNG  
WICHTIG**

**ATTENTION  
IMPORTANTE**

**ATTENZIONE  
IMPORTANTE**

**ATENCIÓN  
IMPORTANTE**



Używaj tylko jednego materaca na każdej części łóżka.

Use only one mattress on each part of the bed.

Verwenden Sie nur eine Matratze auf jedem Teil des Bettes.

Utilisez uniquement un matelas sur chaque partie du lit.

Usa solo un materasso su ogni parte del letto.

Usa solo un colchón en cada parte de la cama.



Nie umieszczaj łóżka blisko okien, zasłon ani żaluzji.

Do not place the bed near windows, curtains, or blinds.

Stellen Sie das Bett nicht in die Nähe von Fenstern, Vorhängen oder Jalousien.

Ne placez pas le lit près des fenêtres, des rideaux ou des stores.

Non posizionare il letto vicino a finestre, tende o persiane.

No coloques la cama cerca de ventanas, cortinas o persianas.



Łóżko można czyścić środkami do pielęgnacji drewna lub delikatnie papierem ściernym, aby usunąć ewentualne zabrudzenia.

The bed can be cleaned with wood care products or gently with sandpaper to remove any dirt.

Das Bett kann mit Holzpflegeprodukten gereinigt oder mit Schleifpapier vorsichtig geschliffen werden, um Verschmutzungen zu entfernen.

Le lit peut être nettoyé avec des produits d'entretien du bois ou délicatement avec du papier de verre pour enlever la saleté.

Il letto può essere pulito con prodotti per la cura del legno o delicatamente con carta vetrata per rimuovere lo sporco.

La cama puede limpiarse con productos para el cuidado de la madera o suavemente con papel de lija para eliminar la suciedad.



Części do łóżka objęte są 2-letnią gwarancją przy normalnym użytkowaniu.

The bed parts come with a 2-year warranty under standard use.

Auf die Bettteile wird eine Garantie von 2 Jahren gewährt bei normalem Gebrauch.

Les pièces du lit sont couvertes par une garantie de 2 ans en cas d'utilisation normale.

I componenti del letto sono coperti da una garanzia di 2 anni con un uso normale.

Las partes de la cama tienen una garantía de 2 años con un uso normal.

## ADDRESS

SMARTWOOD  
Łazy 103a  
37-550 Radymno

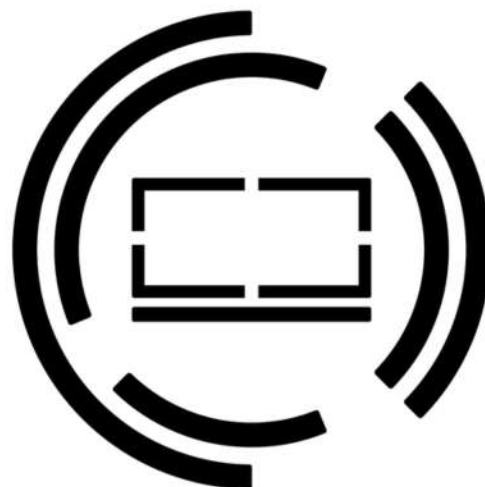

# smartwood®

## CONTACT

**PL**

shop@smartwood.pl  
+48 535 982 922

**ENG/DE/FR/IT/ES**

\*Support only in German and English

shop@smartwood.de  
+49 160 98618205

smartwood.pl

smartwood.de

SCAN  
ME

